



ABOVE & BEYOND



DEFENDER

ON-ROAD

On-road attributes deliver all round breadth of capability. The vehicle is optimised to give the driver the best experience, as well as ensuring the vehicle is safe. The New Land Rover Defender delivers a direct, fun and engaging driving experience on the road, with exceptional all-terrain abilities.

STEERING FEEL

Defender has its own character behind the wheel, one of fun and enjoyment, just as the original did. A dual-pinion Electric Power Assisted Steering system ensures a connected and mechanical drive experience

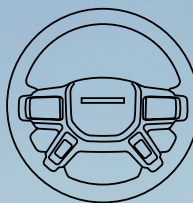

COMMAND DRIVING POSITION

The driver's seating position is paired to a wide, upright windscreen and side mirrors that have been moved forward by 100mm to ensure visibility combined with capability

AWD

All-Wheel Drive ensures capability with composure, delivering torque to the wheel with the most traction, even on split-mu surfaces

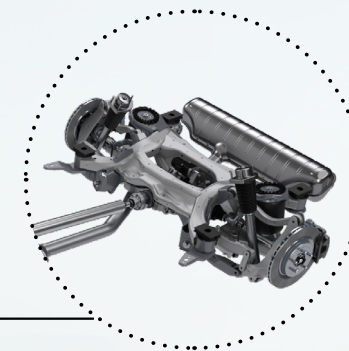

SUBFRAMES

Forged steel subframes help create an incredibly strong structure that delivers a comfortable and assured drive, while also ensuring the durability required for Defender

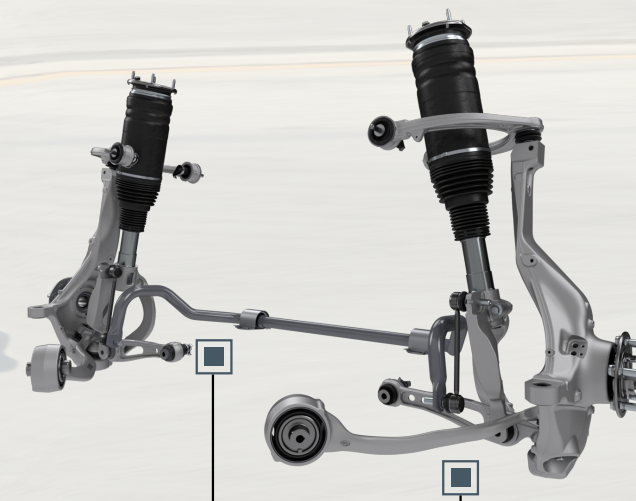

AIR SUSPENSION

Fully independent air suspension irons out any bumps in the road, as well as raising the vehicle to get over extreme obstacles and lowering it for easy entry and egress

MULTI-LINK SUSPENSION

A multi-link suspension is inherently stiff, delivering great refinement on the road. It allows more control over longitudinal and lateral movements, ensuring absolute confidence no matter the surface

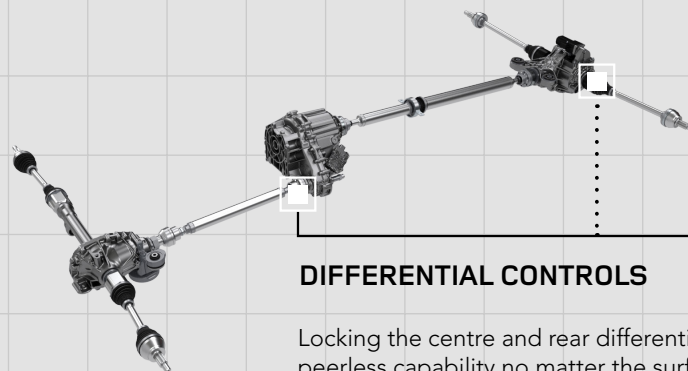

DIFFERENTIAL CONTROLS

Locking the centre and rear differentials ensures peerless capability no matter the surface, as well as allowing cross-axle slip ensuring a dynamic experience on-road